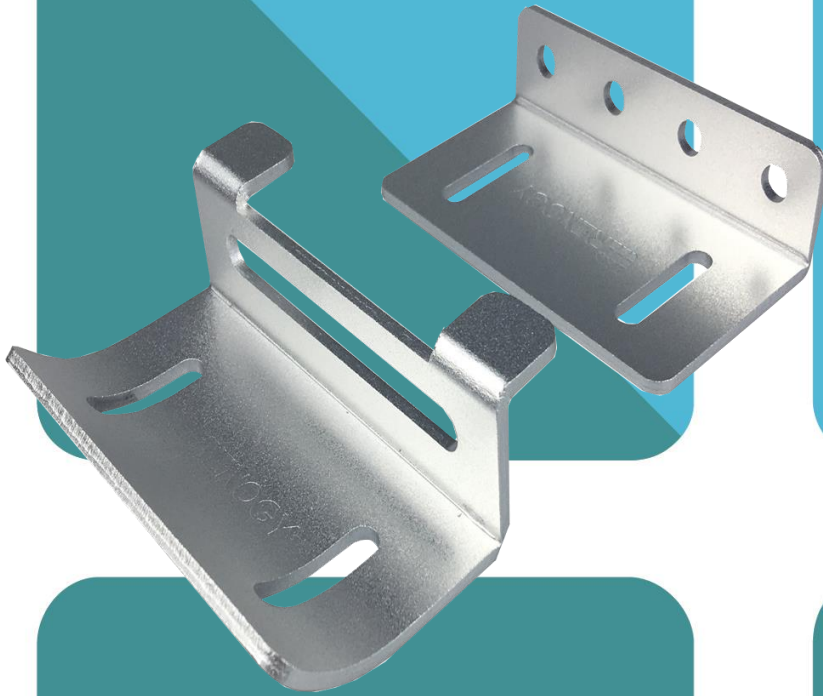


MTS-ACB

RENOGY Photovoltaic Module
Adjustable Curved Bracket



2775 E Philadelphia St, Ontario, CA 91761
1-800-330-8678

Important Safety Instructions

Please save these instructions.

This manual contains important safety, installation, and operating instructions for the Renogy Adjustable Curved Bracket Mount hardware system. The following symbols are used throughout the manual to indicate potentially dangerous conditions or important safety information.

 **WARNING:** Indicates a potentially dangerous condition. Use extreme caution when performing this task.

CAUTION: Indicates a critical procedure for safe and proper operation of the system.

NOTE: Indicates a procedure or function that is important to the safe and proper operation of the system.

General Safety Information

- Read all of the instructions and cautions in the manual before beginning the installation.
- Installation should be completed by a professional contractor to avoid damages that may be incurred due to improper sealing.
- Do **NOT** substitute parts from other manufacture ring sources, doing so may void the warranty and/or result in an unstable system
- This system does **NOT** possess any compliance with residential structural codes and should not be used in place of a system that is, if required by local regulations

Installer Responsibilities

- Installation compliance with any applicable codes which are in force at the installation site
- Installation compliance and compatibility with all system components and the environment including but not limited to roofing, system components, etc.
- Verification that all project information is accurate

Table of Contents

General Information	4
Identification of Parts.....	5
Installation	7
Mating Brackets to Panel Frame	9
Install Panel to General Flat Mounting Surface	14
Install Panel to flat RV Roofs	19
Install Panel to General Mounting Curved Surface	27
Adjustable Curved Bracket Dimensions	28
Compatibility	30

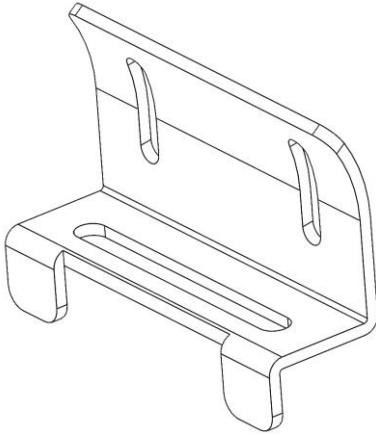
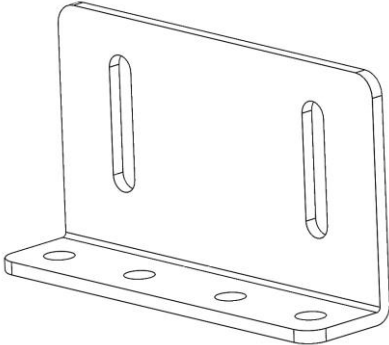
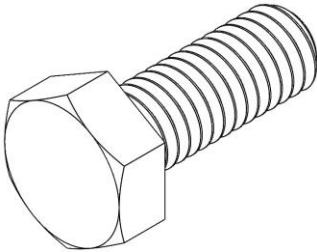
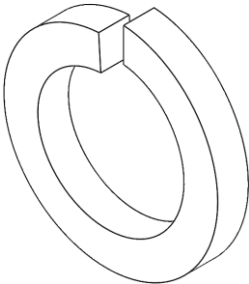
General Information

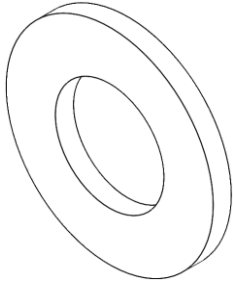
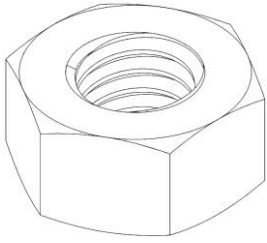
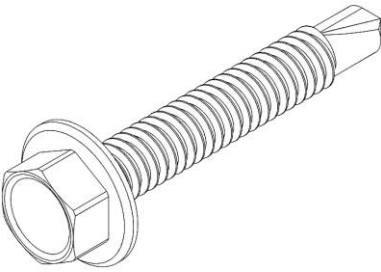
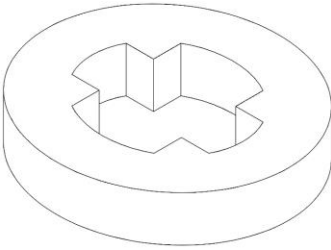
The Renogy Adjustable Curved Bracket Mount System is designed to support the installation of single panel units, generally in off-grid installations. The unique design enables these units to support solar panels on curved surfaces, such as those found on Airstreams and other types of RVs. The system comes complete with all fasteners to secure the system to the installation surface. This system makes the installation of small solar systems easy, affordable and quick.

Key Features

- Lightweight
- Aluminum corrosion-free construction
- Ideal for RV's and boats
- Fits to curved surface. Accept about 30° curve.
- Ease of installation

Identification of Parts

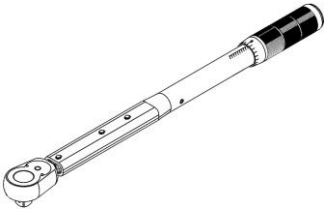
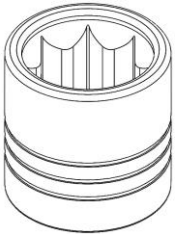
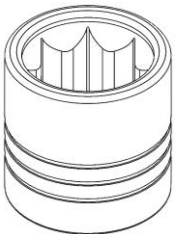
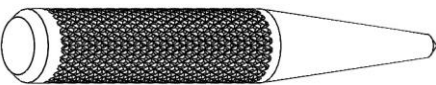

Image	Component	Qty.	Description
	Curved Bracket (A)	4	Main component. Attached to panel frame using the included fasteners.
	Straight Bracket (B)	4	Main component. Attached to the Curved Bracket and secures panels to mounting surface using the included fasteners.
	M6 x 16mm Hex Cap Bolt (C)	12	Fastener used to attach Curved Bracket to panel, and attach Straight Bracket to Curved Bracket. Material: Stainless Steel
	M6 Split Lock Washer (D)	4	Deformable washer which creates a spring force from deformation. Provides the necessary preload to cap bolt. Used on cap bolts for fixing Curved Bracket and panel together


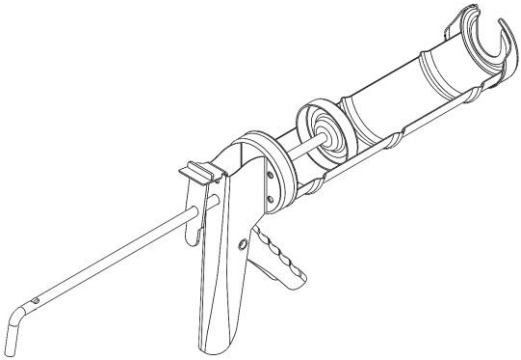
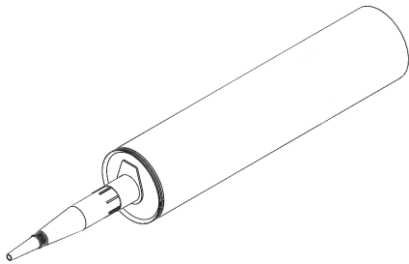
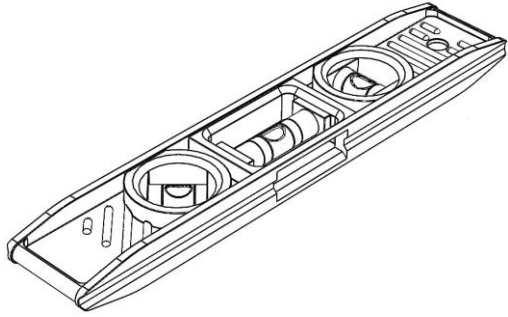
	<p>M6 Flat Washer (E)</p>	<p>16</p>	<p>Normal flat washer used to prevent surface marring on components from the use of the Lock Washers and Nuts.</p>
	<p>M6 Hexagonal Nut (F)</p>	<p>12</p>	<p>Used to tighten down joint between components and panel.</p>
	<p>#10 x 1¼ in Self-Drilling Cap Screw (G)</p>	<p>16</p>	<p>Screw capable of self-drilling into the mounting surface. Used to secure Straight Bracket to the mounting surface. Material: Steel</p>
	<p>Plastic Retaining Ring (H)</p>	<p>16</p>	<p>Placed between the self-drilling screws and Straight Bracket. Should come threaded over self-drilling screws in package.</p>

Installation

Recommended tools to have before installation:

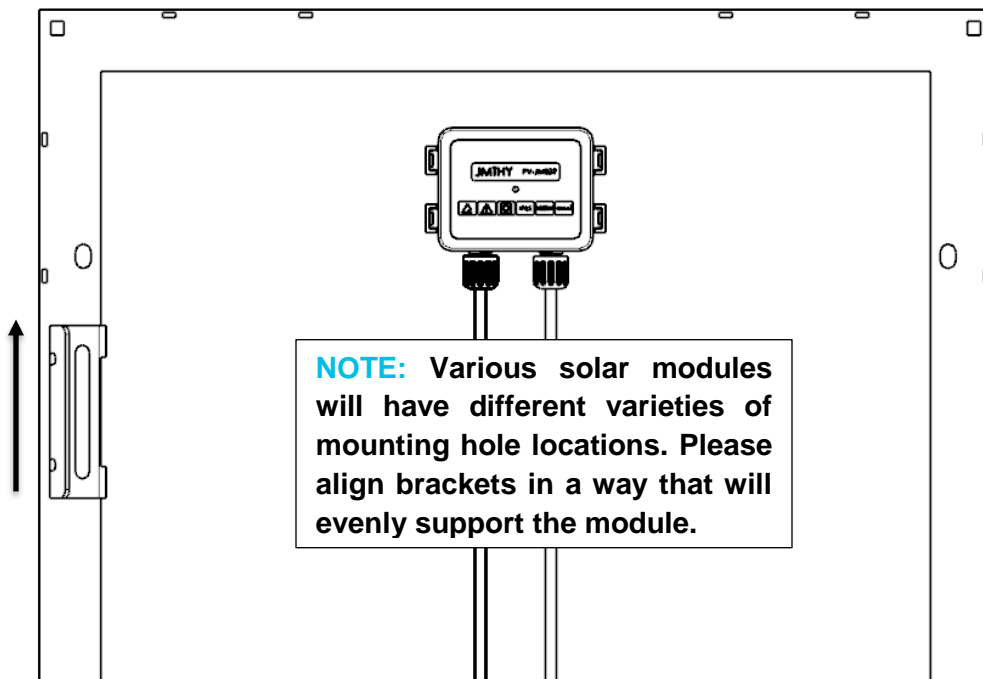
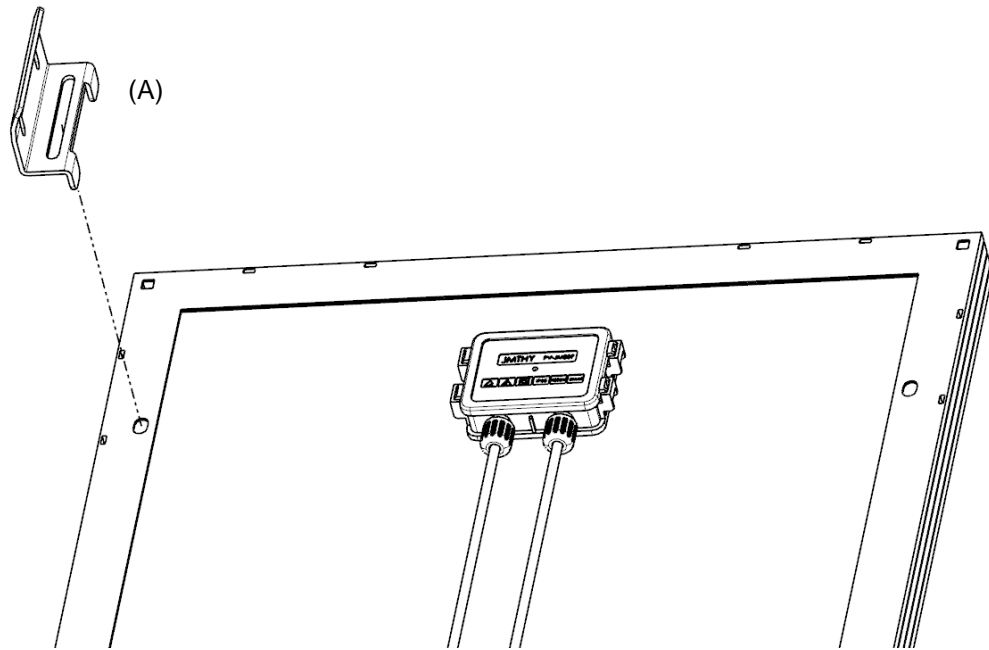
The following tools and equipment are highly recommended to have available to assist with installation but are in no way a comprehensive list of tools that can ease installation. Installers feel free to substitute comparable equipment where appropriate.

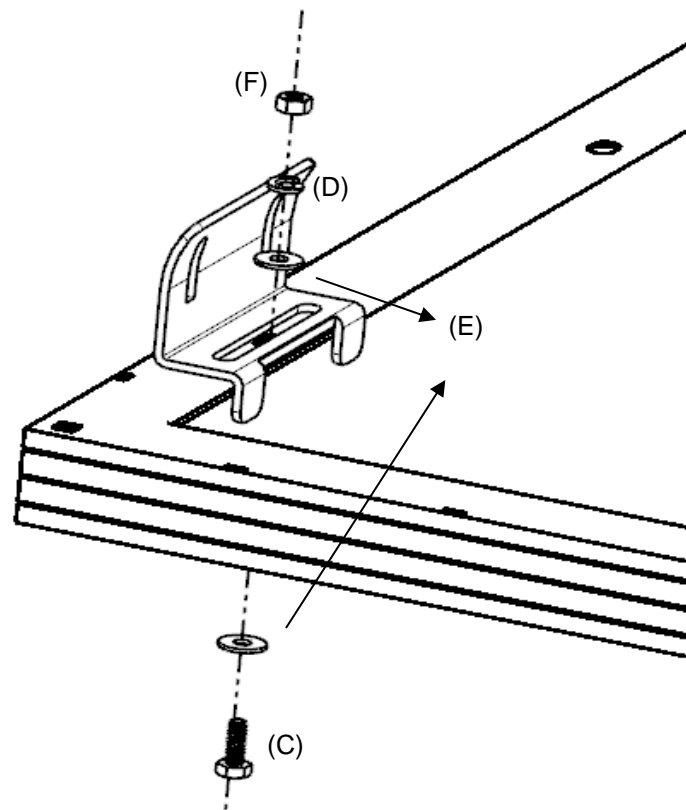
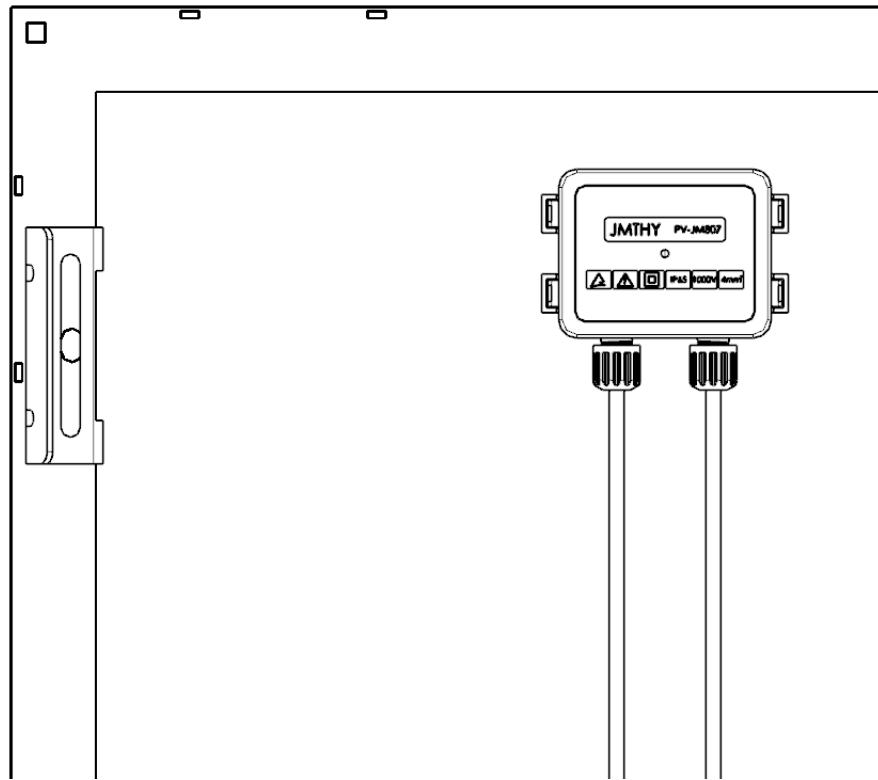
Image	Component	Description
	Ratchet/Torque Wrench	Allows for tightening of fasteners. Torque wrench allows for careful monitoring of torque value to prevent overtightening.
	6mm Socket Drive	Used with ratchet to tighten down bolted joint between panel and bracket.
	5/32" Socket Drive	Used with ratchet to drive screw into mounting surface and secure bracket to it.
	Center Punch	Indents mounting surface to reduce screw wandering during initial drive.
	Crescent Wrench	Used to prevent rotation of the nut during joint tightening until split lock washer has effectively engaged.

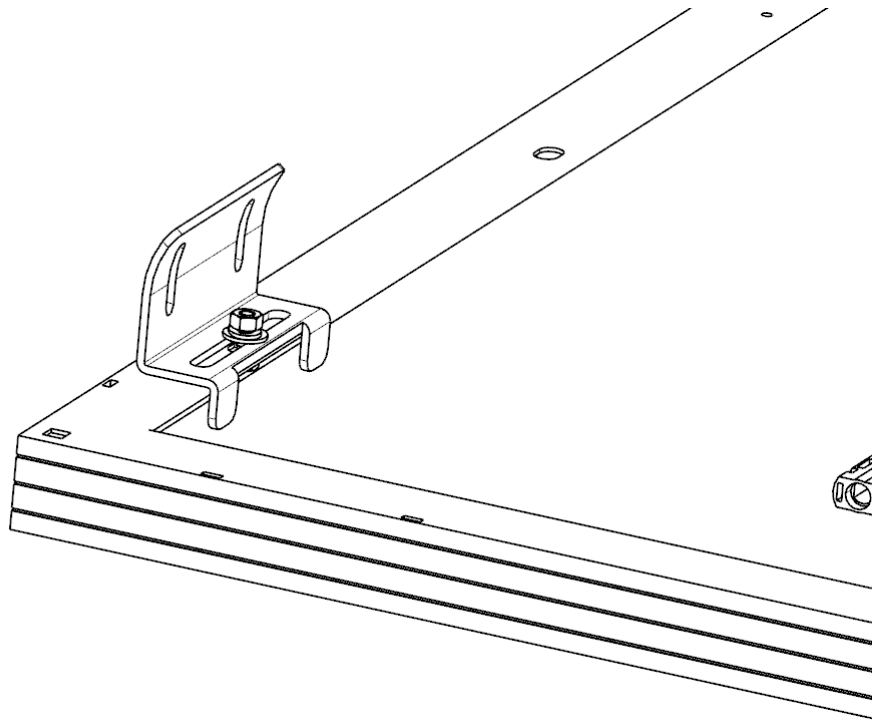
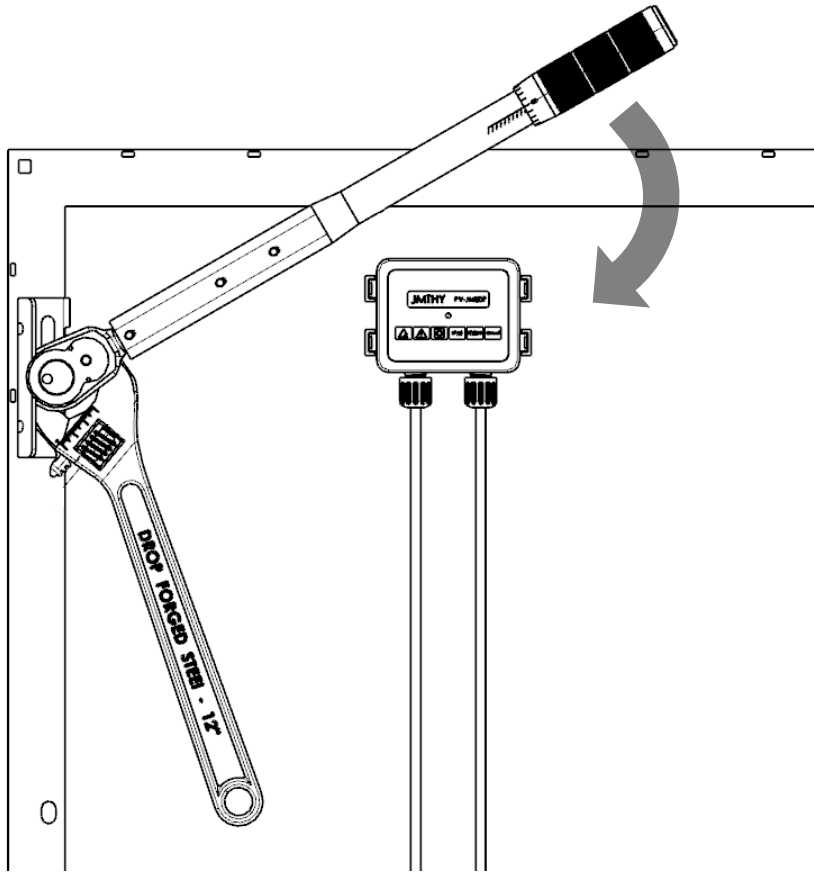
	<p>Tape Measure</p>	<p>May be useful in planning Bracket configuration and positioning.</p>
	<p>Caulking Gun</p>	<p>Used to direct sealant into penetrations to avoid leaking.</p>
	<p>Compatible Sealant</p>	<p>Sealant compatible with your specific installation.</p>
	<p>Spirit Level</p>	<p>Used to ensure panel is level and/or plumb to the mounting surface and orientation.</p>

⚠ WARNING: Installation on shingle roofs is not recommended. System is not designed with these roof types in mind. Fasteners will not penetrate framing deep enough and will likely cause heavy issues with leaking.

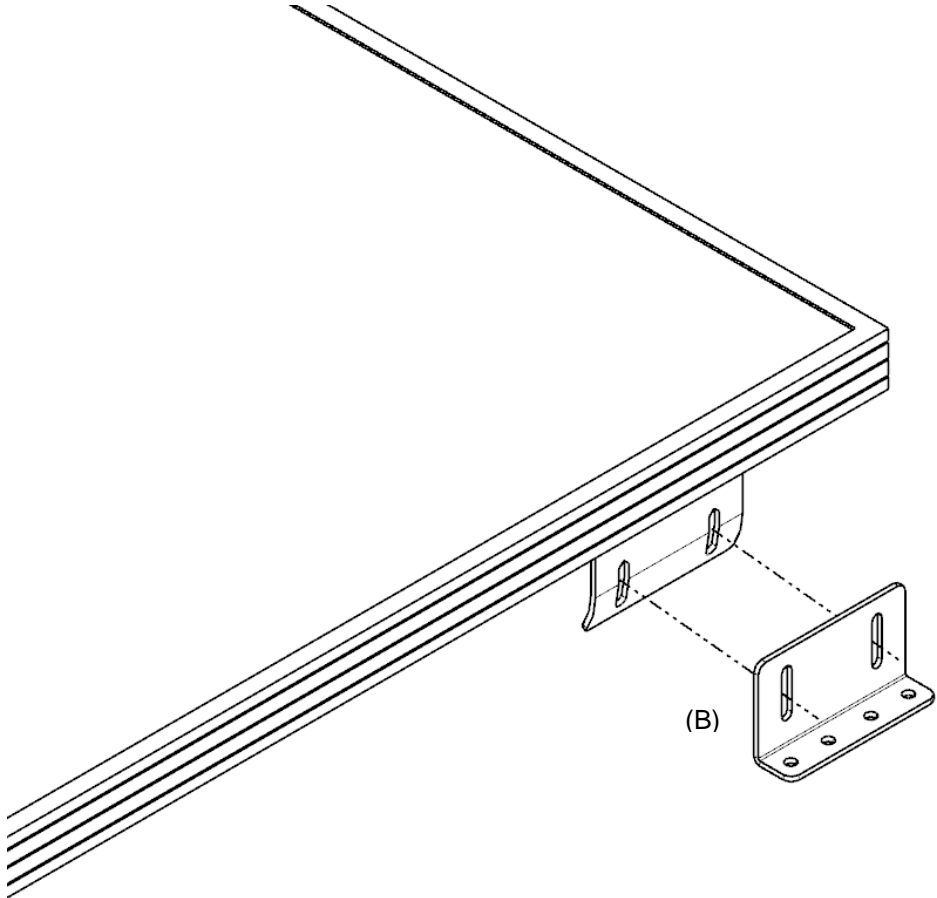
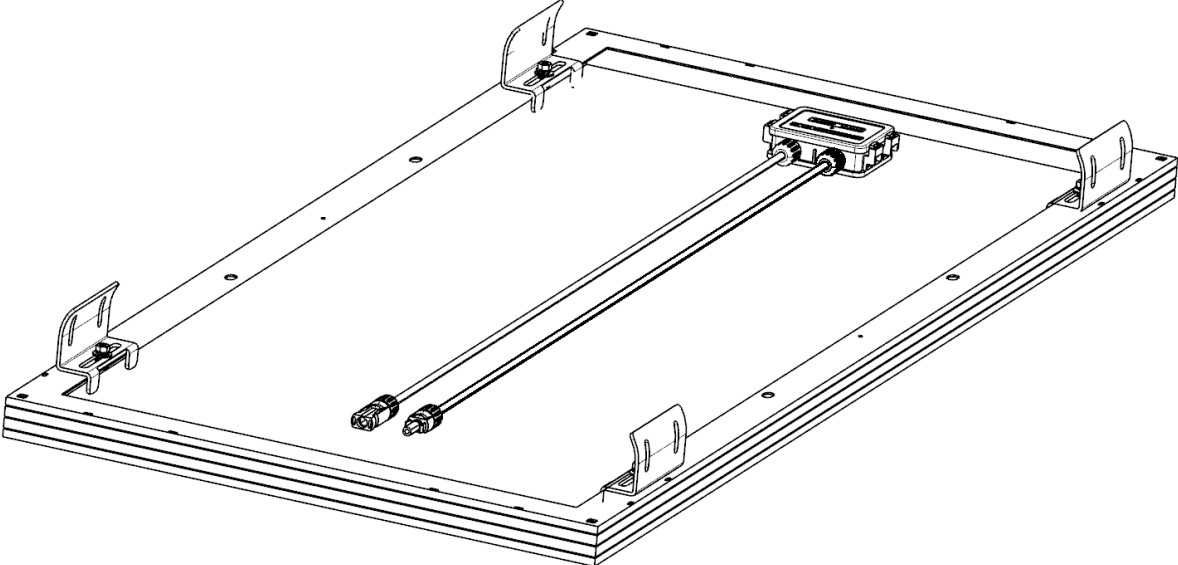
Mating Brackets to Panel Frame

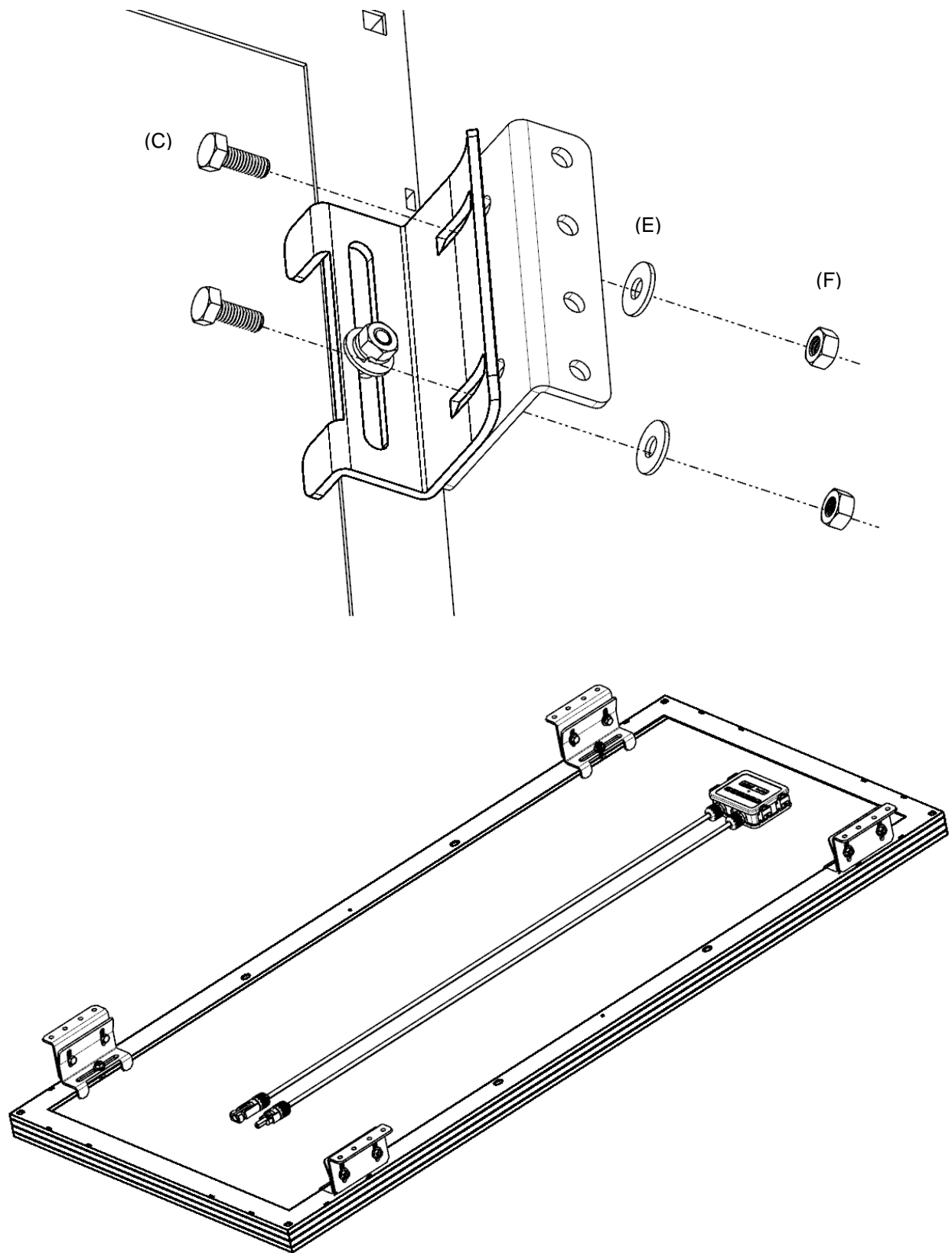




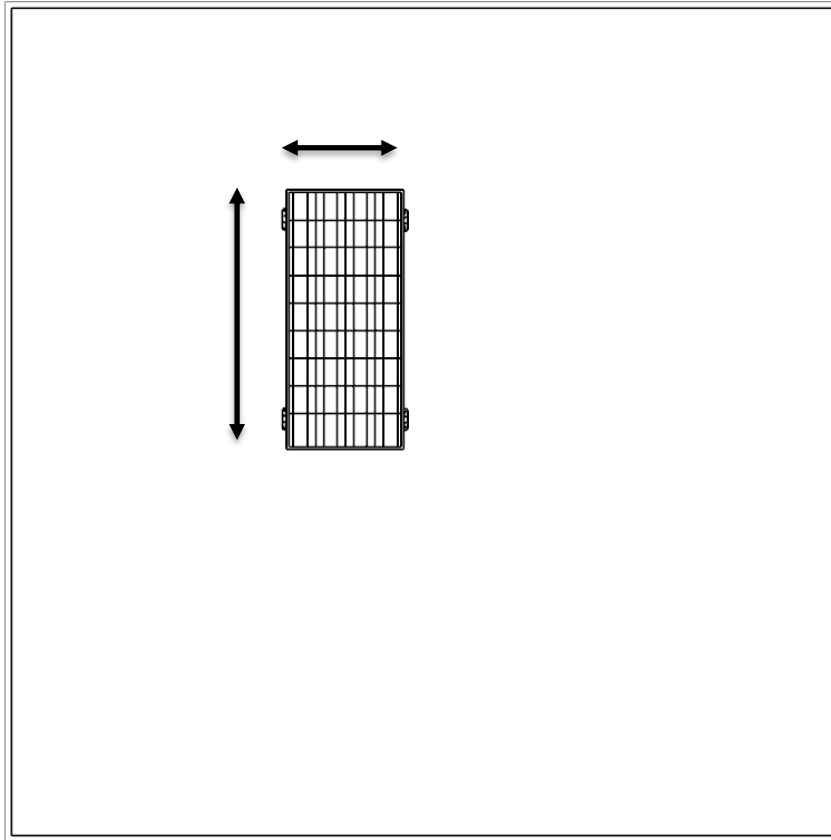


Repeat for each Curved Bracket in the set at each corner.

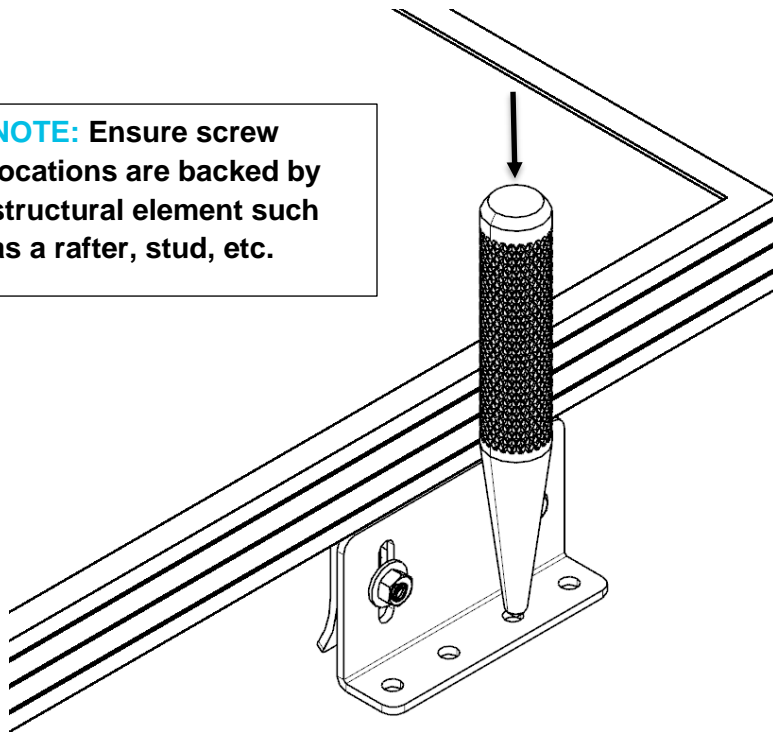


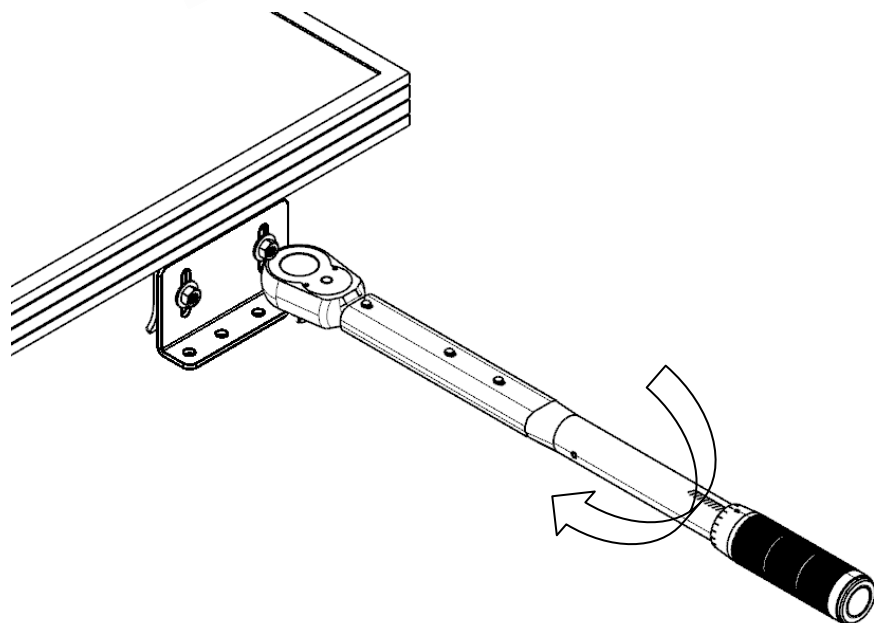
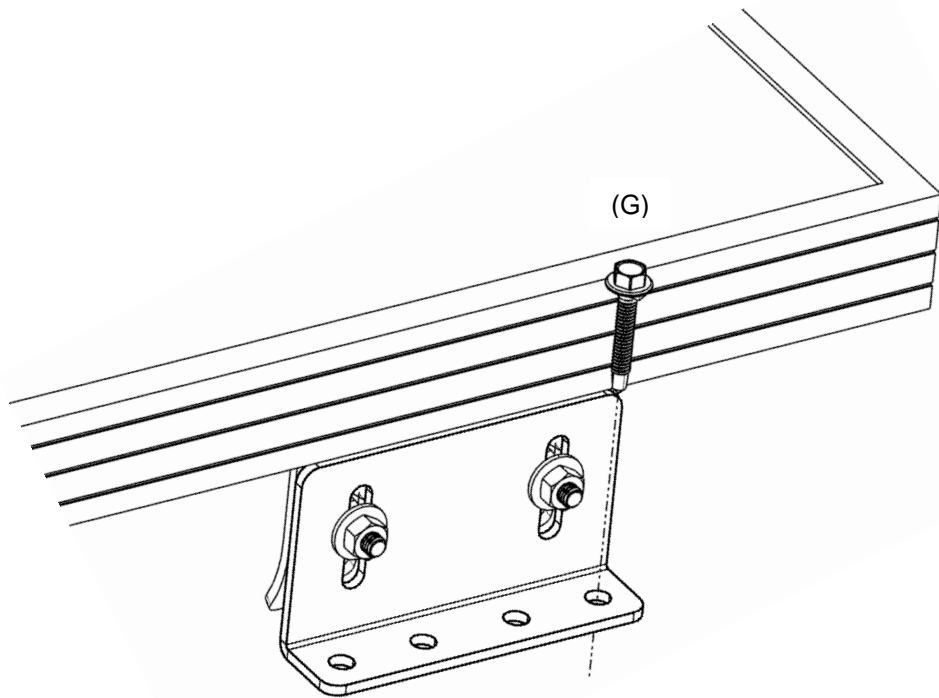


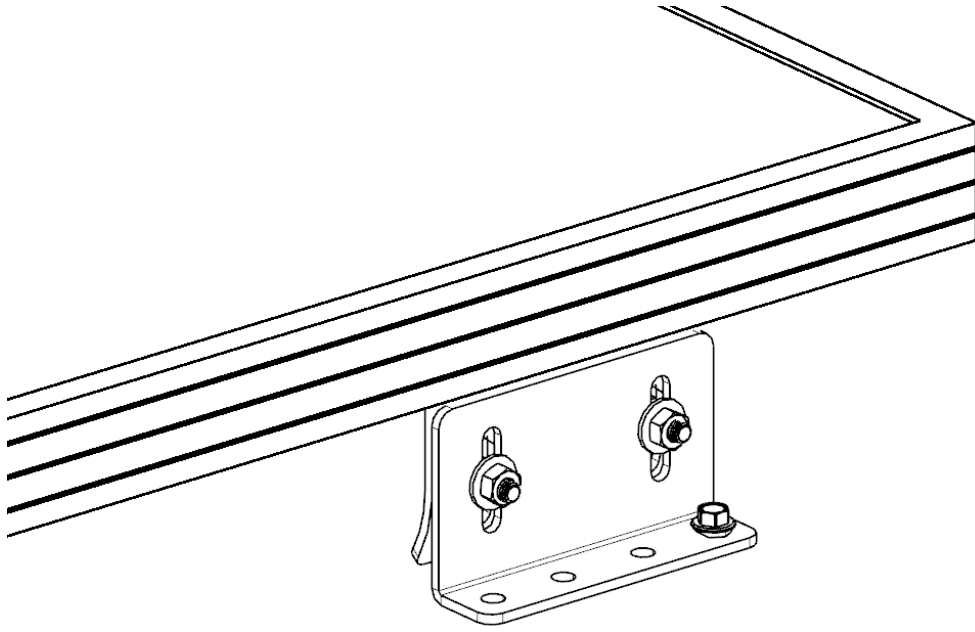
Install Panel to General Flat Mounting Surface



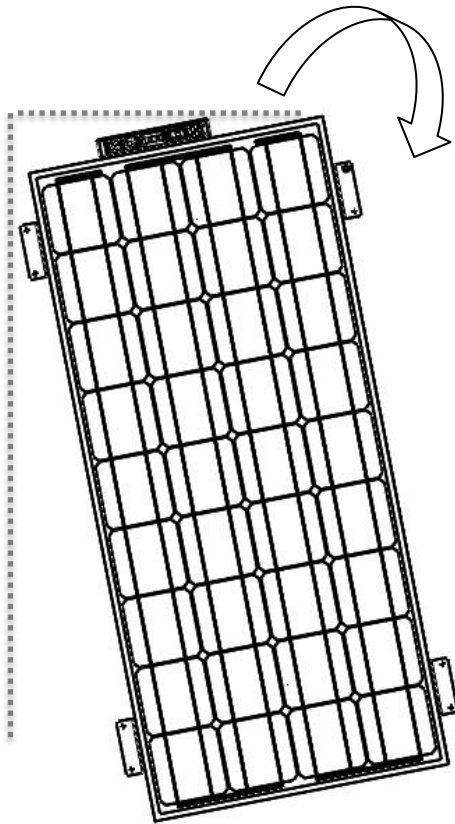
NOTE: Ensure screw locations are backed by structural element such as a rafter, stud, etc.

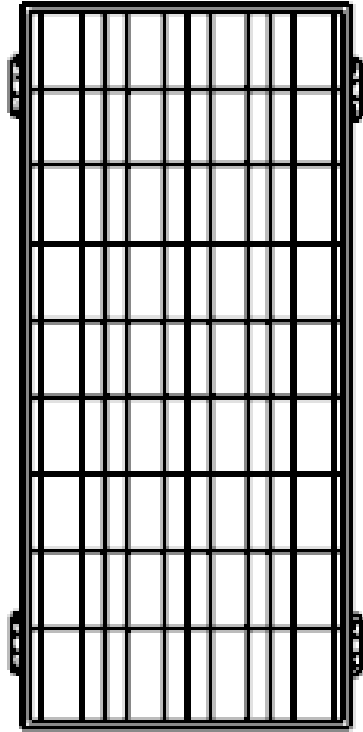






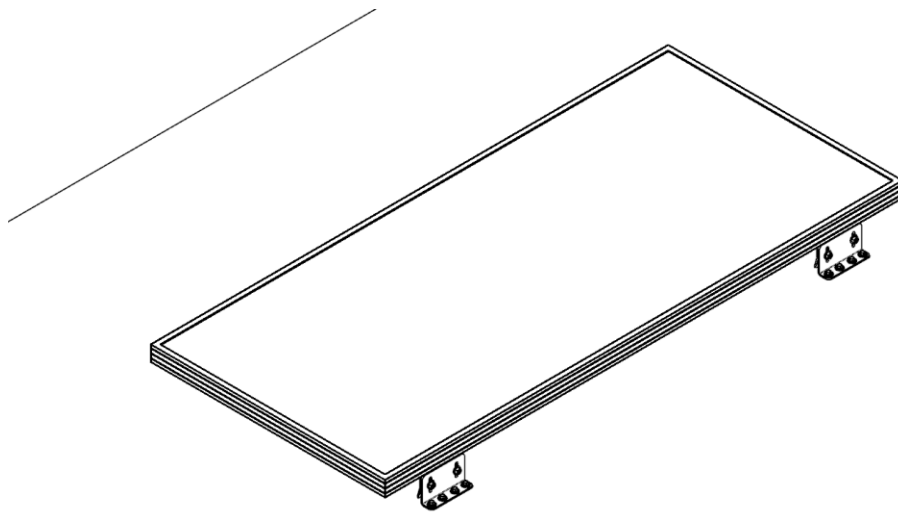
NOTE: Orient panel in level/plumb layout as desired before fixing in position.

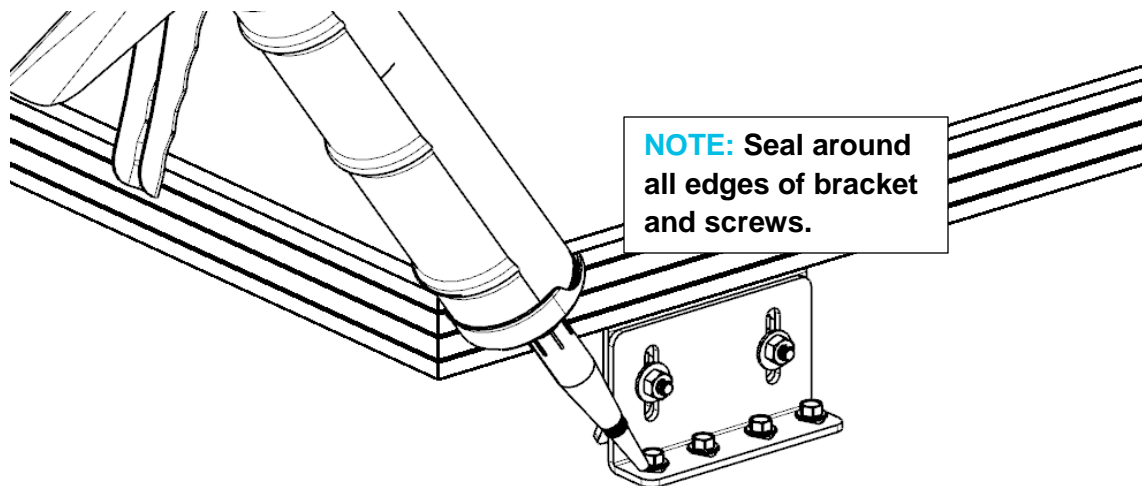




NOTE: Begin new fastener at indicated location first to secure panel in level plumb/level layout.

Repeat for all fastener locations.





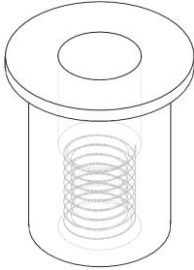
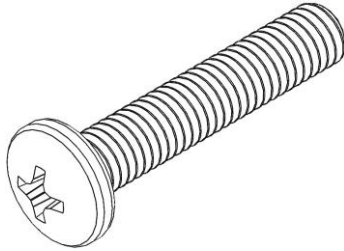
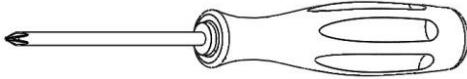
Repeat for all brackets.

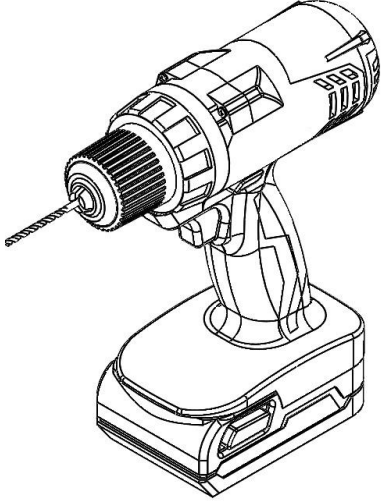

Install Panel to flat RV Roofs

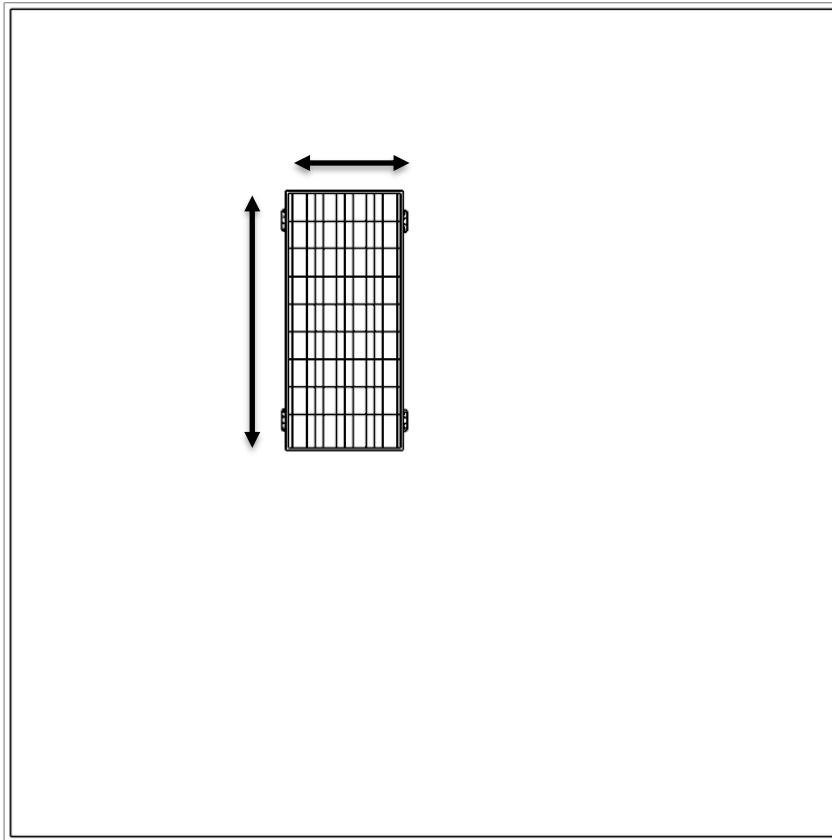
Installation on to the roofs of RV's typically requires more specialized instruction due to the nature of construction of most commercially available RV roofs. Please note that this section includes the use of a fastener type **NOT** included in the Bracket kit. This section is included for convenience of customers installing to an RV roof. The instructions listed in this section are a modification of the normal installation, all other steps are to be completed normally.

NOTE: A minimum roof thickness of 3/8" is recommended for this type of installation.

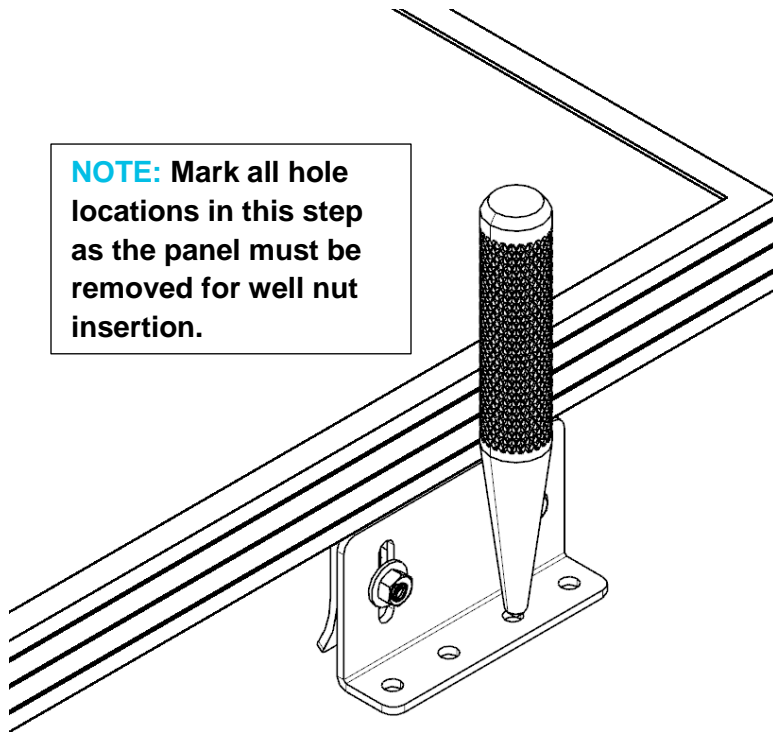
Additional components and tools required for this section:

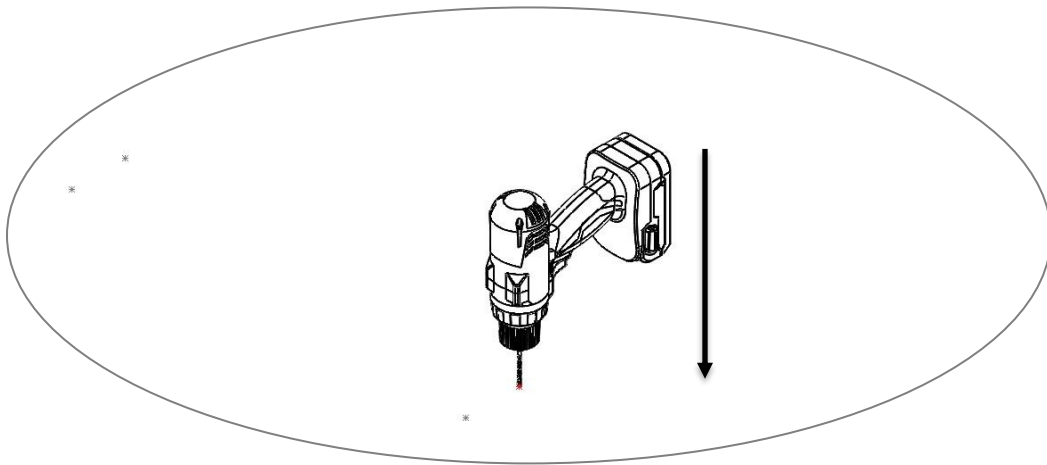
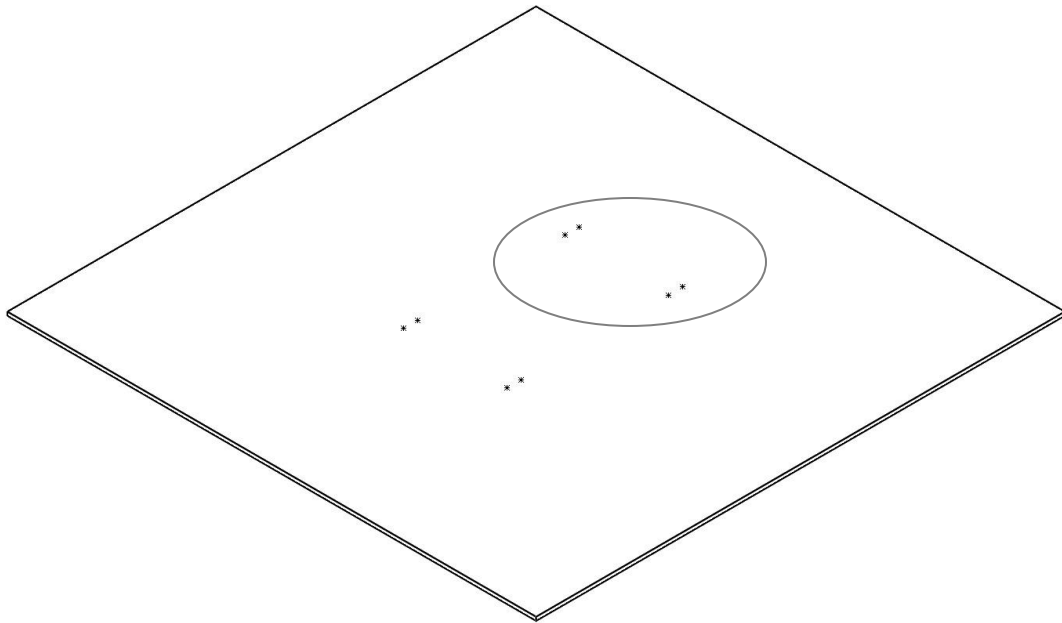
Image	Component	Description
	Well Nut (I)	<p>Special recessed fastener which expands as the internal fastener is tightened. Allows for fastener to seal within mounting surface and embed itself tightly. Need variety with at least #10-32 internal thread, material thickness supporting roof thickness, and 3/8" hole size. A fastener with suggested features can be found here:</p> <p>http://www.mcmaster.com/#93495a190/=xfp203</p> <p>http://www.homedepot.com/p/Everbilt-10-32-tpi-x-5-8-in-Brass-Expansion-Nut-814358/204276054</p>
	Machine Screw (J)	<p>Used to secure Brackets to surface with well nut. Must be compatible with chosen well nut by having the same internal thread and not longer than the length of the well nut. Must also purchase compatible flat and lock washers.</p>
	Phillips Head Screw Driver (K)	<p>Used to secure machine screw into well nut.</p>

	<p>Cordless Drill</p>	<p>Used to drill clearance holes for well nuts in roof top.</p>
	<p>Drill Bit</p>	<p>Used with Cordless Drill to create clearance holes for the well nuts. Must be matched to the well nut's outer diameter. Recommended variety requires 3/8" bit.</p>

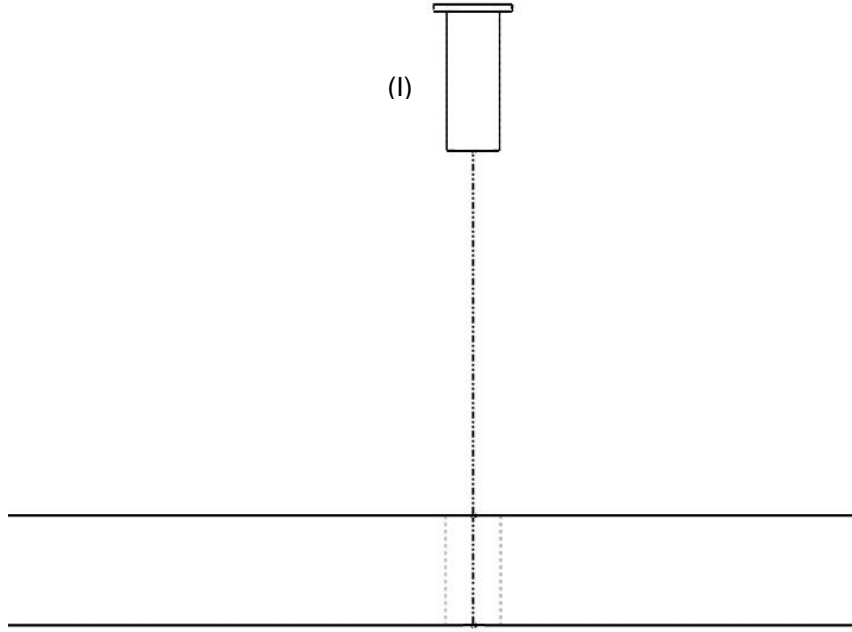


NOTE: Mark all hole locations in this step as the panel must be removed for well nut insertion.

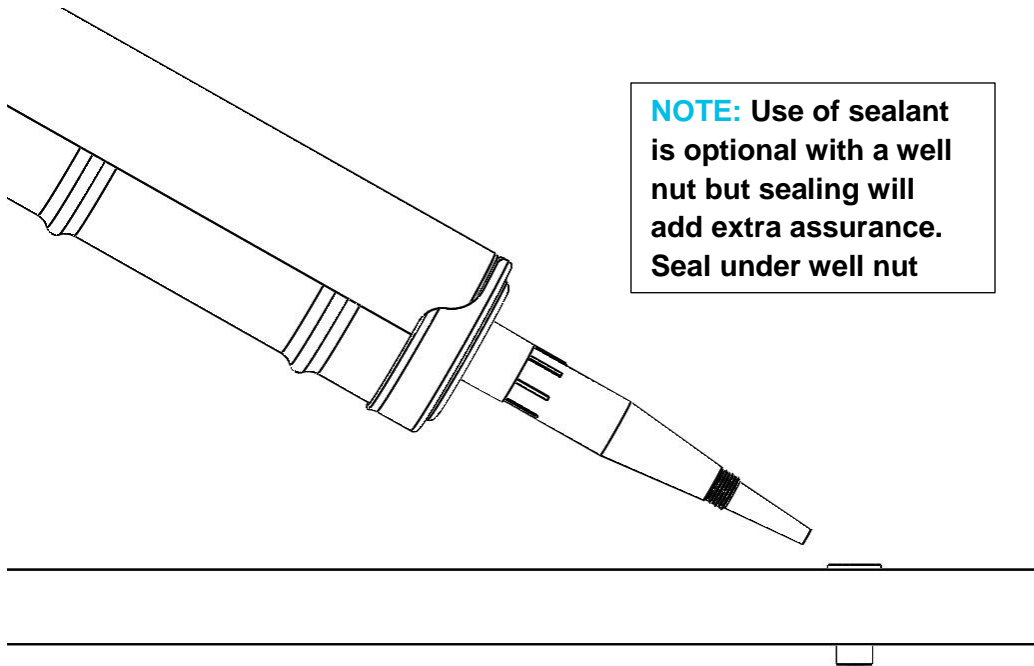




(1)

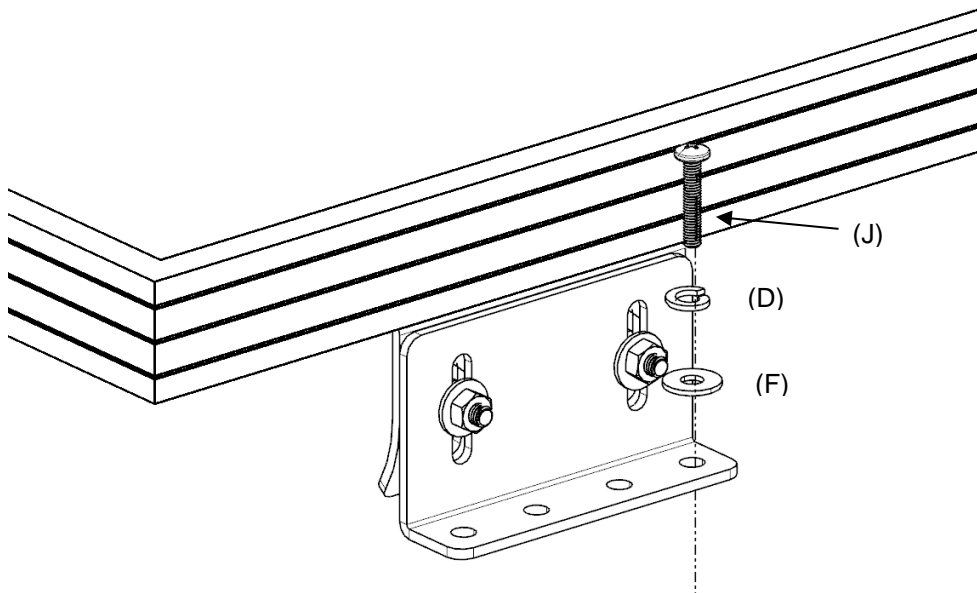
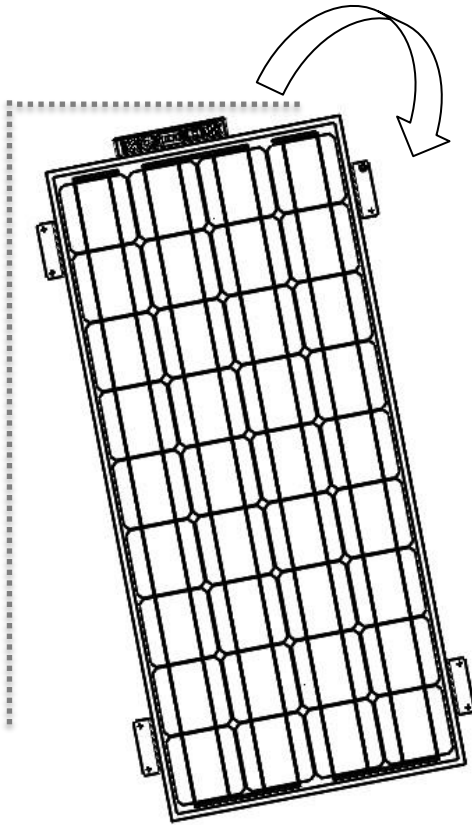


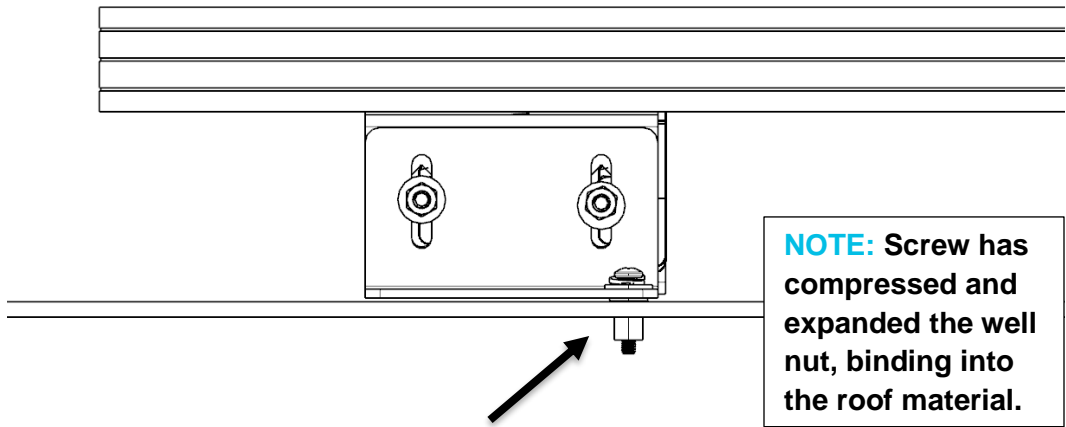
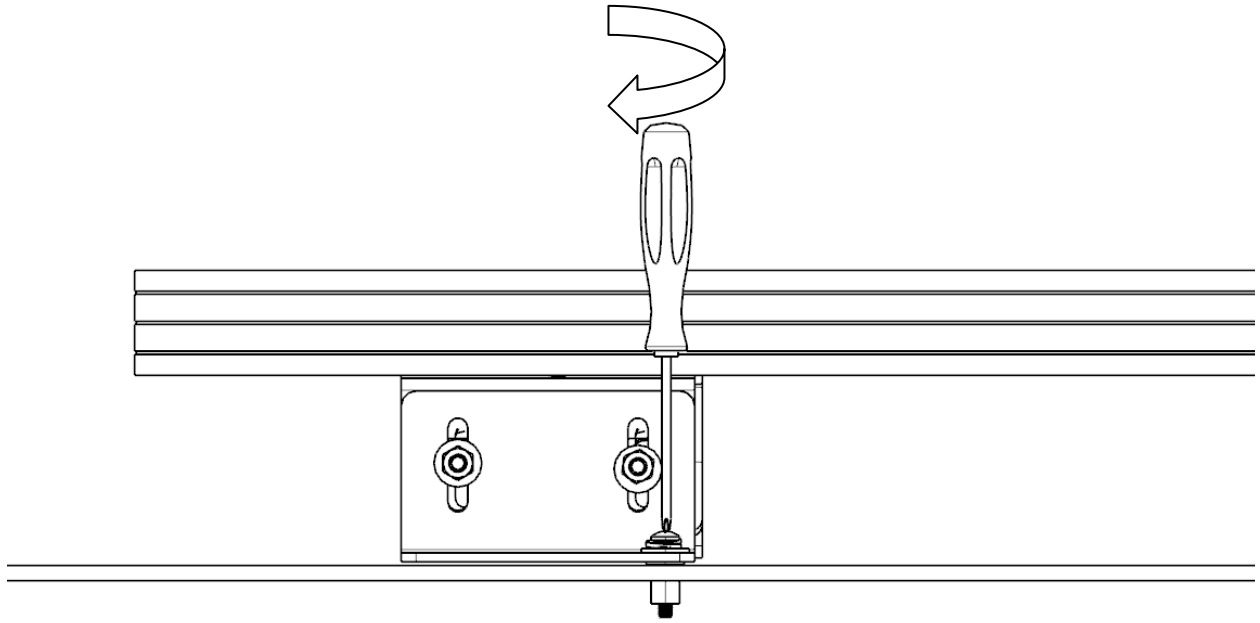
NOTE: Use of sealant is optional with a well nut but sealing will add extra assurance. Seal under well nut



Repeat for all holes.

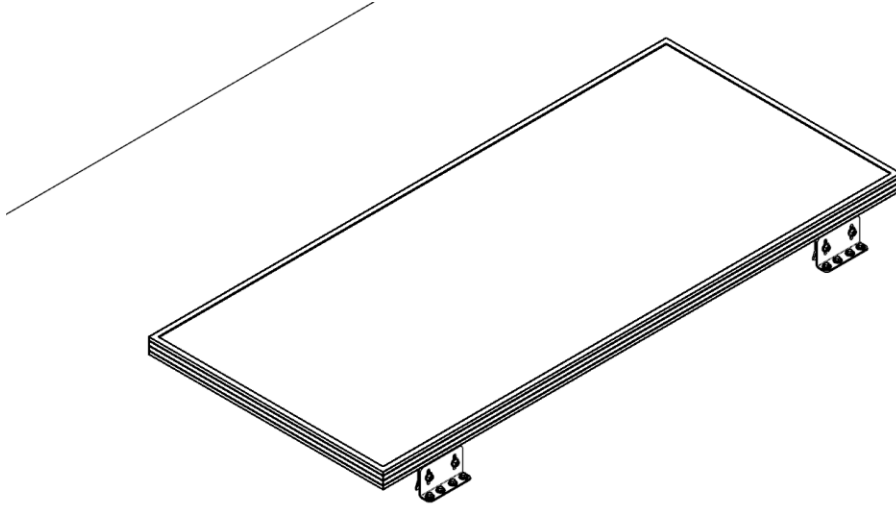
NOTE: Orient panel in level/plumb layout as desired before fixing in position.





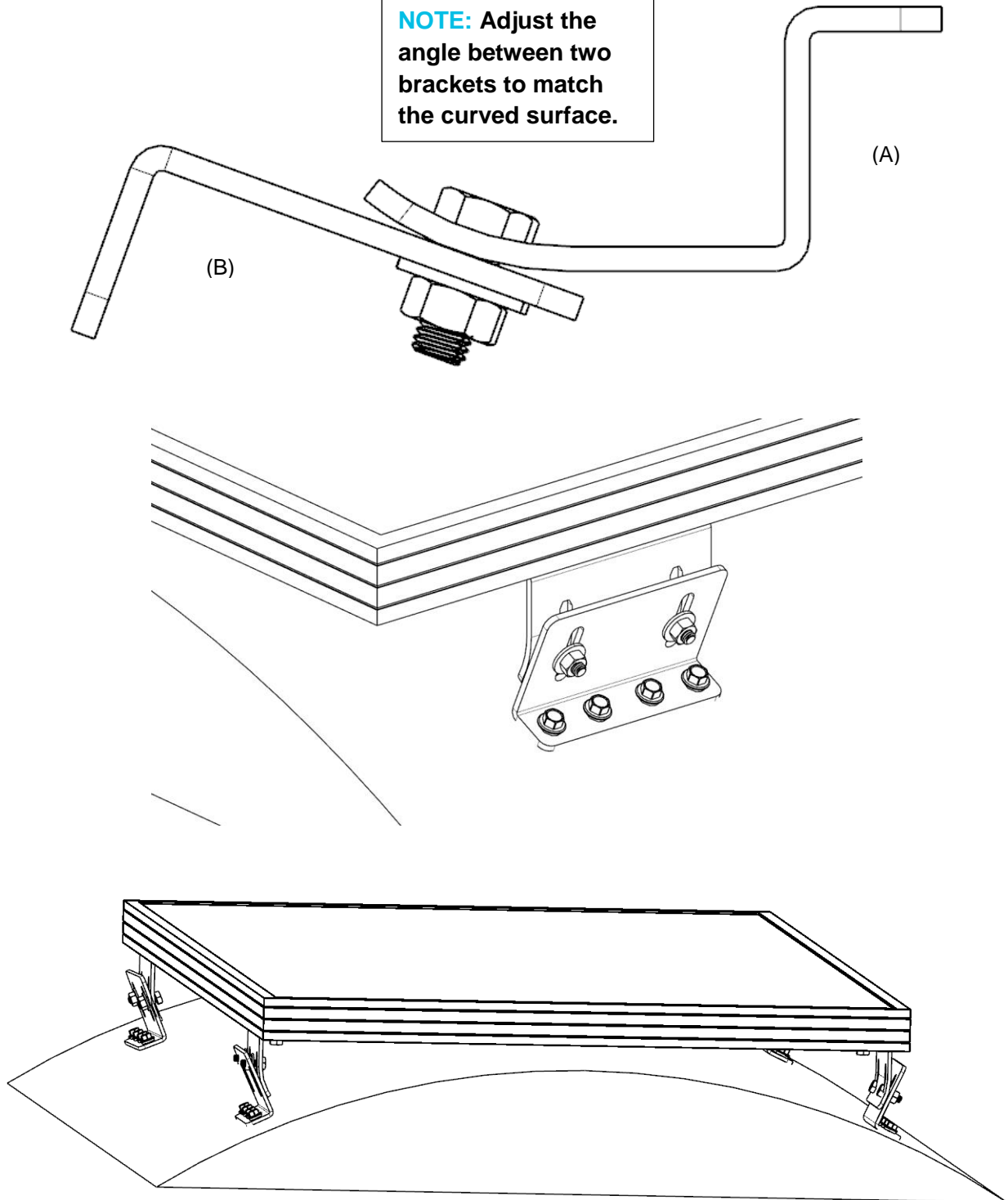
NOTE: Screw has compressed and expanded the well nut, binding into the roof material.

Repeat for all fasteners.

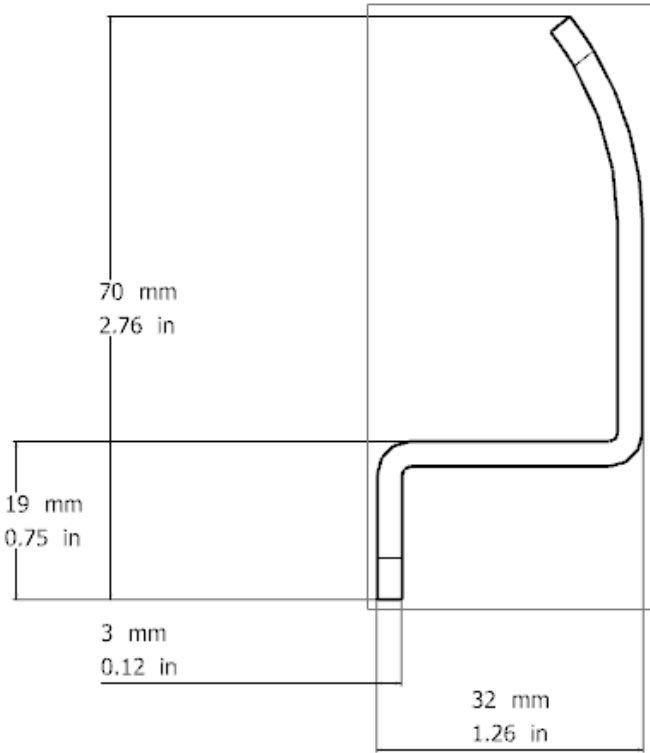
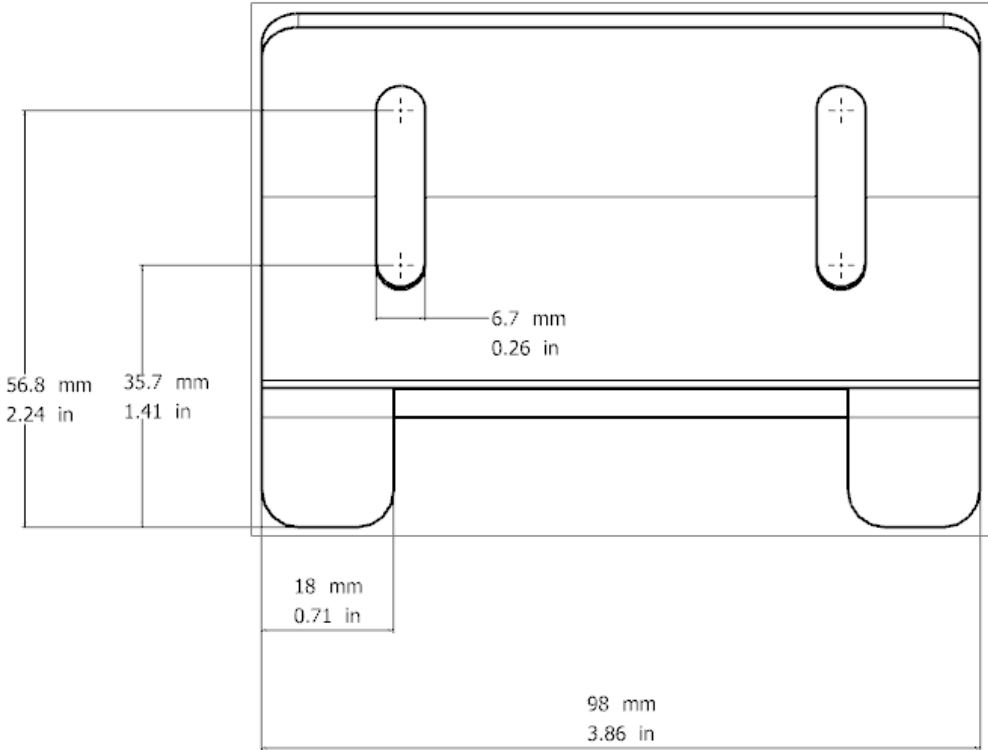


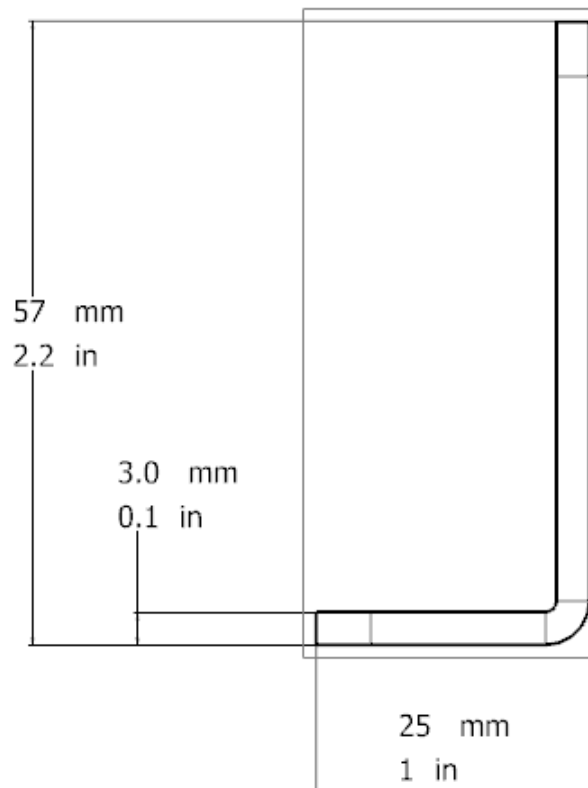
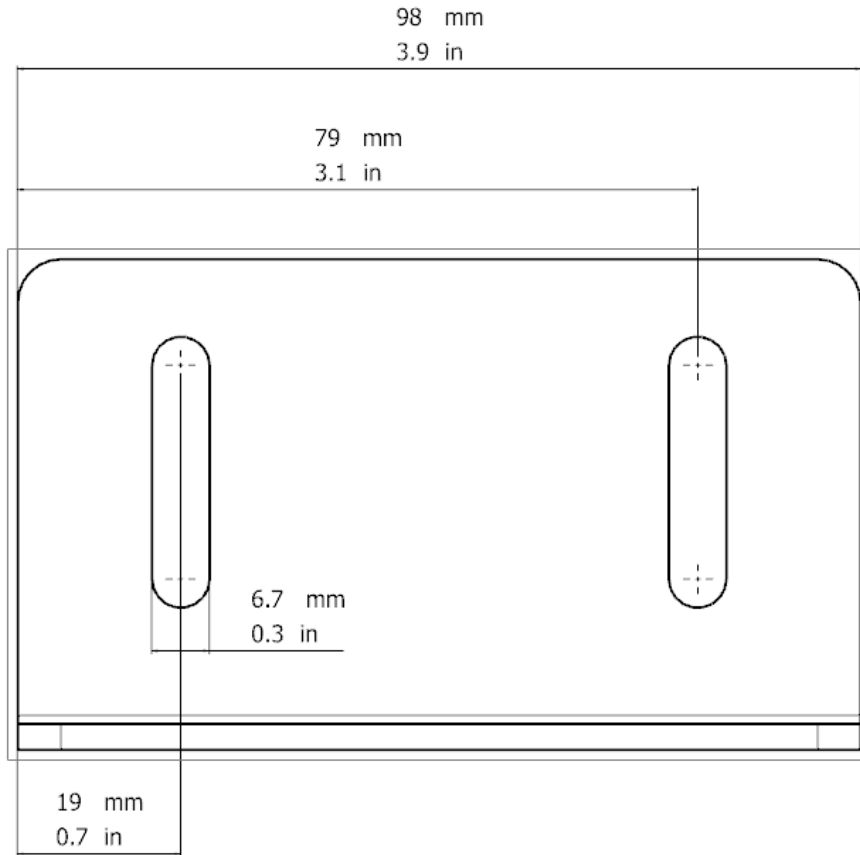
Install Panel to General Mounting Curved Surface

NOTE: Adjust the angle between two brackets to match the curved surface.



Adjustable Curved Bracket Dimensions





Compatibility

RENOGY Solar Module	Compatibility*
RNG-10D	COMPATIBLE
RNG-10D-SS	COMPATIBLE
RNG-20D	COMPATIBLE
RNG-30D	COMPATIBLE
RNG-30D-SS	COMPATIBLE
RNG-50D	COMPATIBLE
RNG-50D-SS	COMPATIBLE
RNG-80D-SS	COMPATIBLE
RNG-100D	COMPATIBLE
RNG-100D-S	COMPATIBLE
RNG-100D-SS	COMPATIBLE
RNG-100D-SSP	COMPATIBLE
RNG-100MB	COMPATIBLE
RNG-100D-R	COMPATIBLE
RNG-160D-SS	COMPATIBLE
RNG-300D	**
RNG-50P	COMPATIBLE
RNG-100P	COMPATIBLE
RNG-160P	COMPATIBLE
RNG-270P	**
RNG-320P	**

*This list is not comprehensive and is intended for an “at-a-glance” look at which solar modules provided by Renogy are compatible with the Bracket Mounting System. Modules provided by other manufacturers may work with the Bracket Mounting System provided the follow conditions are met:

- 1) Solar module weight does not exceed 88 lbs (40 kg) or total load per bracket does not exceed 22 lbs (10 kg).
- 2) Solar module framing material is constructed of an aluminum alloy.
- 3) If using a panel oriented such that the distance between Brackets along an edge exceeds 39 in (1 m), it is advisable to add Brackets for mid-span support. Lack of mid-span support can cause excessive stress in the module under load and may result in solar module damage. Consult with your solar module manufacturer if you are unsure of the compatibility.

**These modules require the installation of 2 Bracket sets to ensure the modules do not excessively flex in their mid-span (a total of 8 pairs of Brackets per module).

Renogy reserves the right to change the contents of this manual without notice.